



RoHS  
compliant



### Description

Openable current sensor providing a measuring signal proportional to the primary current  $I_p$ . 2 output scales are available (at  $I_{PN}$  and at  $I_{PMAX}$ ). The 2 outputs are adjusted with the standard  $\pm 10V$  and / or  $\pm 20mA$ .

Exist with plug-in screwable connector or shielded cable.

Design and industrialization protected by patents.

### Aimed applications

Inverters (UPS), windmills, rectifiers, electrolysis, harmonics active filter, drives.

Any application requiring an important opening for the passage of the primary conductor (cable, bars or set of bars).

### Options

Other nominal ratings or measuring range on request.

### Description

Capteur de courant ouvrable fournissant un signal de mesure proportionnel au courant primaire  $I_p$ . 2 échelles de sortie sont disponibles (à  $I_{PN}$  et à  $I_{PMAX}$ ). Les 2 sorties sont réglées au standard  $\pm 10V$  et / ou  $\pm 20mA$ .

Existe avec sortie connecteur enfichable à vis ou câble blindé.

Conception et industrialisation protégées par brevets.

### Applications visées

Onduleurs (UPS), éoliennes, redresseurs, électrolyse, filtre actif d'harmoniques, variateurs de vitesse.

Toute application nécessitant une ouverture importante pour le passage du conducteur primaire (câble, barre ou jeu de barres).

### Options

Autres calibres nominaux ou plage de mesure à la demande.



# SENSOR / CAPTEUR

Issued: 2006.11.29

Commercial family  
Famille commerciale  
**NCS305VF**

Application  
Application  
**INDUSTRY**

Modification : 4  
Date : 2013.04.10  
**Page 2/5**

C\_NCS\_4.doc

<b>Commercial reference</b> Référence Commerciale	NCS305-6 VF	NCS305-10 VF	NCS305-20 VF
<b>Order code</b> Référence de commande	ISBT200306R0102	ISBT200310R0102	ISBT200320R0102

## CHARACTERISTICS / CARACTERISTIQUES

**Electrical : Primary current / Electrique : Courant Primaire**

<b>Nominal primary current (I<sub>PN</sub>)</b> Courant primaire nominal (I <sub>PN</sub> )	<b>A peak</b> A crête	6000	10000	20000	
<b>Measuring range (I<sub>P</sub> max)</b> Plage de mesure (I <sub>P</sub> max)	<b>A peak</b> A crête	20000	30000	40000	
<b>Not measurable overload</b> Surcharge non mesurable	<b>A peak</b> A crête	80000	120000	200000	: (1s/h)

**Electrical : Output voltage / Electrique : Sortie Tension**

<b>Secondary voltage (V<sub>S1</sub>) at I<sub>PN</sub></b> Tension secondaire (V <sub>S1</sub> ) à I <sub>PN</sub>	<b>V peak</b> V crête	±10	
<b>Secondary voltage (V<sub>S2</sub>) at I<sub>PMAX</sub></b> Tension secondaire (V <sub>S2</sub> ) à I <sub>PMAX</sub>	<b>V peak</b> V crête	±10	
<b>Offset voltage (V<sub>S10</sub>)</b> Tension résiduelle (V <sub>S10</sub> )	<b>mV</b>	≤ ±100	: (@ +25°C)
<b>Offset voltage (V<sub>S20</sub>)</b> Tension résiduelle (V <sub>S20</sub> )	<b>mV</b>	≤ ±50	: (@ +25°C)
<b>Thermal drift coefficient</b> Coefficient de dérive thermique	<b>mV/°C</b>	≤ ±2	
<b>Measuring resistance (R<sub>M</sub>)</b> Résistance de mesure (R <sub>M</sub> )	<b>Ω</b>	10000 ... ∞	

### OUTPUTS

A primary current flowing in the direction of the arrow results in a positive output current from Is1 or Is2 terminals and in a positive voltage on Vs1 or Vs2 terminals.

### SORTIES

Un courant primaire circulant dans le sens de la flèche engendre un courant positif sortant aux bornes Is1 ou Is2, et une tension positive aux bornes Vs1 ou Vs2.

**Output voltage / Sortie tension**

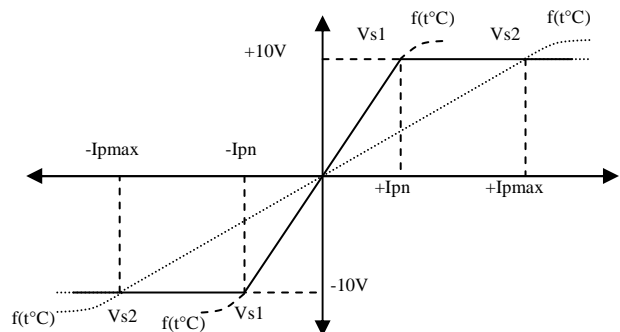

PETERCEM . com

Noncontractual text & photographs

## CHARACTERISTICS

## CARACTERISTIQUES

Accuracy r.m.s. (without offset) <sup>1</sup> at $I_{PN}$	Précision eff. (sans offset) <sup>1</sup> à $I_{PN}$	%	: $\leq \pm 1$ (@ +25°C)
Accuracy r.m.s. (without offset) <sup>1</sup> at $I_{PMax}$	Précision eff. (sans offset) <sup>1</sup> à $I_{PMax}$	%	: $\leq \pm 3$ (@ +25°C)
Gain thermal drift	Dérive thermique du gain	%/°C	: $\leq 0.01$ (-20 ... 85°C)
Gain thermal drift	Dérive thermique du gain	%/°C	: $\leq 0.04$ (-40 ... -20°C)
Linearity (typical)	Linéarité (typique)	%	: $\pm 0.5$
Delay time (typical)	Temps de retard (typique)	$\mu$ S	: $\leq 10$
di/dt correctly followed	di/dt correctement suivi	A/ $\mu$ s	: $\leq 100$
Bandwidth	Bande passante	kHz	: 0 ... 10 (@ -1dB)
No-load consumption current ( $I_{A0+}$ )	Courant de consommation à vide ( $I_{A0+}$ )	mA	: $\leq 400$ (@ -40°C)
Dielectric strength	Rigidité diélectrique		
Primary / Secondary	Primaire / Secondaire	KV r.m.s. (kV eff.)	: 5 (50Hz, 1min)
Supply voltage $V_A$	Tension d'alimentation $V_A$	V d.c.	: +15 ... +24 ( $\pm 2\%$ )
Mass	Masse	Kg	: 5.8
Operating temperature	Température de service	°C	: -40 ... +85
Storage and start-up temperature	Température de stockage / démarrage	°C	: -50 ... +90
Temperature of primary conductor in contact with the sensor	Température du conducteur primaire en contact avec le capteur	°C	: $\leq 100$



# SENSOR / CAPTEUR

Issued: 2006.11.29

**Commercial family**  
*Famille commerciale*  
**NCS305VF**

**Application**  
*Application*  
**INDUSTRY**

**Modification : 4**  
**Date : 2013.04.10**  
**Page 4/5**

## Particularities

## Particularités

**Burn-in test according to cycle**

*Déverminage suivant cycle*

: FPTC404304

<sup>1</sup>**Accuracy in 50Hz**

<sup>1</sup>*Précision à 50Hz*

**A r.m.s. (A eff.)**

: ≤ 5000 (ac 50Hz)

<sup>1</sup>**Max. generated I<sub>PN</sub> current**

<sup>1</sup>*Courant I<sub>PN</sub> max. généré*

**For best measuring performances, the primary conductor should be mounted centred through the sensor (see mounting instructions)**

*Pour des meilleures performances de mesure, le conducteur primaire doit être monté centré à l'intérieur du capteur (voir instructions de montage)*

## Protections :

## Protections :

**-Of the measuring circuit against short-circuits**

*-Du circuit de mesure contre les court-circuits*

**-Of the measuring circuit against opening**

*-Du circuit de mesure contre l'ouverture*

**-Of the power supply against polarity reversal**

*-De l'alimentation contre les inversions de polarité*

## Standards

## Normes

**Industry**

*Industrie*

: EN50178

: EN61000-6-4

: EN61000-6-2

C\_NCS\_4.doc



AEROSPACE  
& DEFENCE



COACHES  
& BUSES



RAILWAY



INDUSTRY



ENERGY



PLEASURE  
BOAT



VERTICAL  
TRANSPORT



INDUSTRIAL  
VEHICLES



OFFSHORE  
& MINING

**PETERCEM . com**

Noncontractual text & photographs

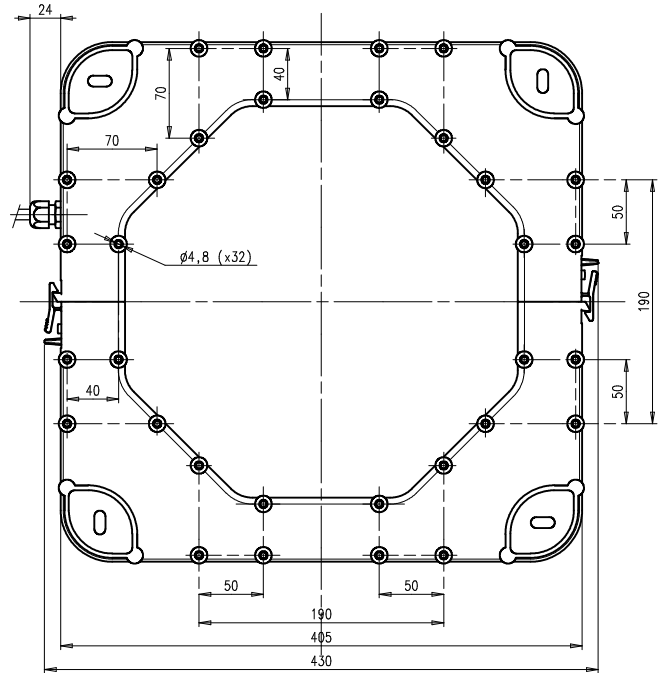
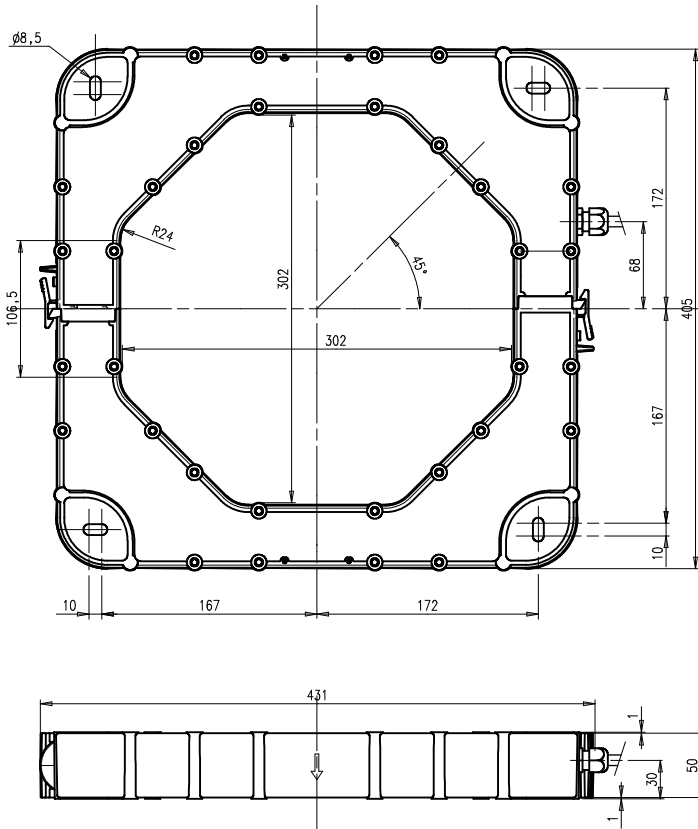

RoHS  
compliant



General tolerance :  $\pm 1$  mm  
Tolérance générale :  $\pm 1$  mm

## GENERAL CONNECTION DIAGRAM / SCHEMA GENERAL DE CABLAGE

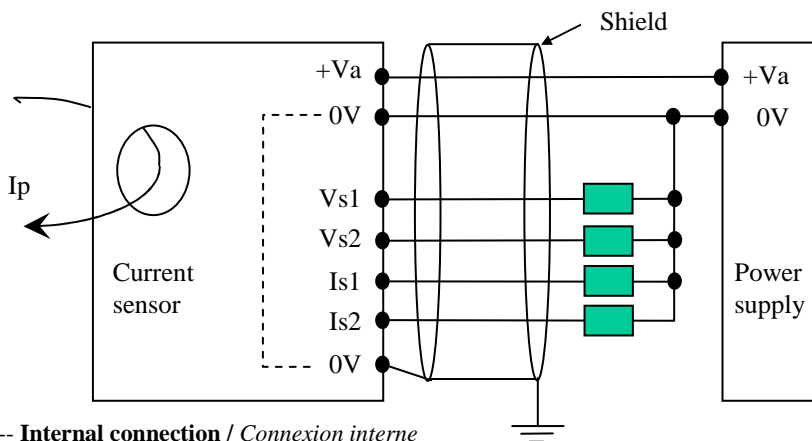

Shielded cable : / Câble blindé :  
6 conductors / 6 conducteurs  
- Section / Section : 0.5 mm<sup>2</sup>  
- Length / Longueur : 2 m  $\pm$  0.1

### TERMINAL MARKING / REPERAGE SORTIES

- 1 : Red / Rouge : +Va (+15 ... +24 Vdc)
- 2 : Black / Noir : 0V
- 3 : Blue / Bleu : NC
- 4 : Green / Vert : Vs1 ( $\pm 10V$  @ Ip<sub>n</sub>)
- 5 : White / Blanc : Vs2 ( $\pm 10V$  @ Ip<sub>max</sub>)
- 6 : NC
- 7 : NC
- 8 : Brown / Marron : 0V
- Shield / Blindage : 0V (Ground)

--- Internal connection / Connexion interne

Instructions for use and mounting according to our documentation / Instructions de montage et d'utilisation suivant notre documentation

C\_NCS\_4.doc